

8 Open up a new flowchart in the Programming Editor.

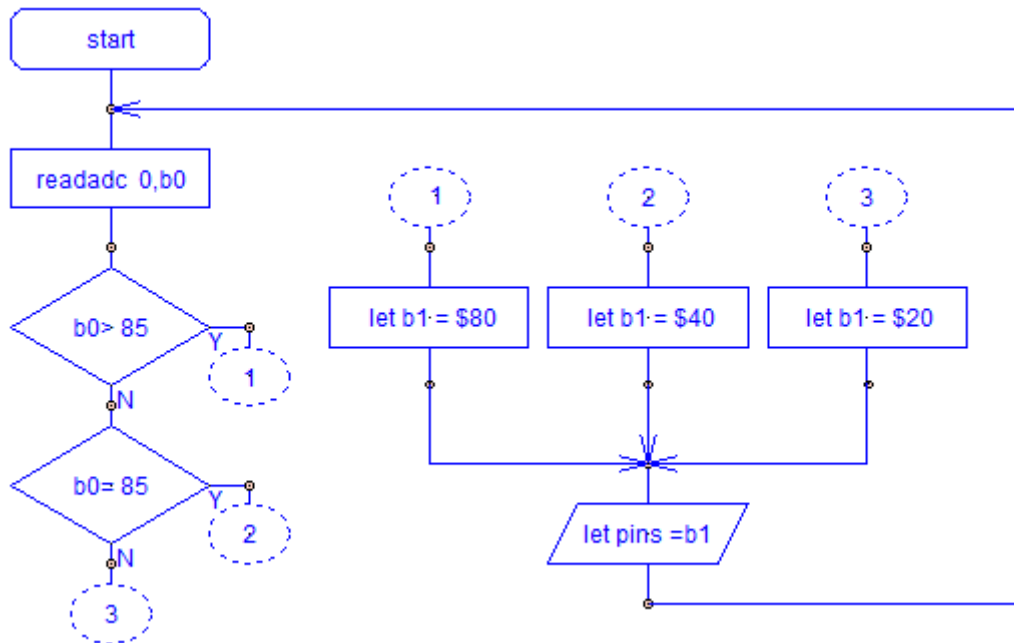

9 Enter the flowchart above as follows:

- use the **other commands** and **readadc** buttons to make the first process box
- click on the **if commands** button, select the appropriate decision box and position it as shown above
- click on the **if commands** button and edit the decision box
- repeat for the other decision box
- click on the **add connection points** button and attach links 1, 2 and 3 as shown above
- click on the **other commands** and **BASIC** buttons
- add three process boxes as shown above and edit accordingly from the keyboard (the \$ sign indicates a byte in hexadecimal)
- click on the **other commands** and **let pins =** buttons to add the output box
- edit the output box from the menu
- attach links 1, 2 and 3 to the inputs of the process boxes
- use the **draw lines** button to connect the process boxes to the output box
- connect the output box to the start of the program, as shown above

10 Download the program into the microcontroller.

11 Complete the sentences for the circuit with the new program.

Z is only high when I_0 is above _____ V.

X is only high when I_0 is below _____ V.

Y is only high when I_0 is between _____ V and _____ V

Digital systems

You are going to evaluate the effect of changing the program of a microcontroller.

- 1 Assemble this circuit. You should already have the LEDs and their series resistors in place.

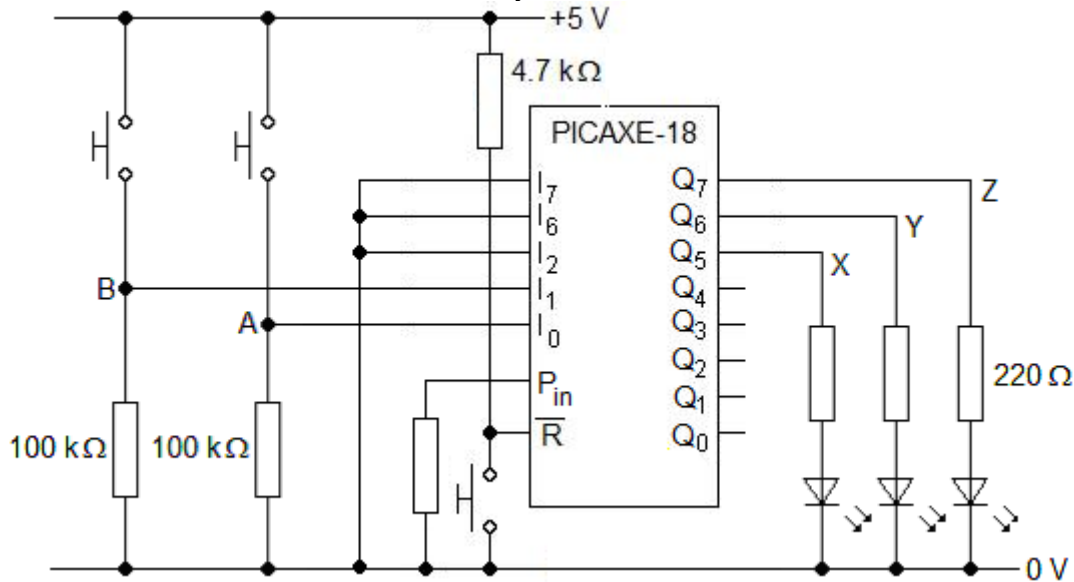

- 2 Write this flowchart into the PICAXE Programming Editor. You will need to use the **output commands** and **BASIC** buttons to generate the **let b3 = pins** input box.

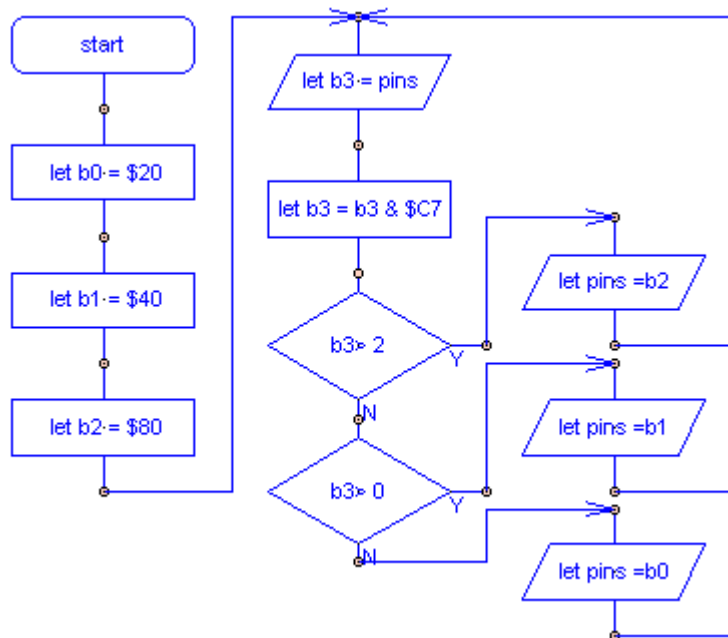

- 3 Download the program into the microcontroller. Find out what happens when you press and release the switches which generate B and A.

- 4 Now write the flowchart opposite into the Programming Editor.
- 5 Download the program into the microcontroller. Find out what happens when you press and release the switches which generate B and A.

