

Multipulse monostable

You are going to assemble and test a one-shot sequencer.

- 1 Assemble this circuit.
- 2 Connect an LED and 220 Ω series resistor to CK via a MOSFET driver.
- 3 Verify that pressing the switch turns the oscillator on, and that connecting R to +5 V turns it off again.

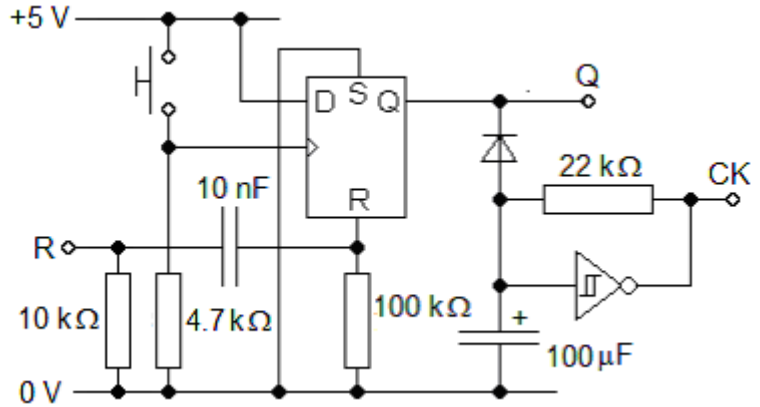

- 4 Add the components shown opposite. Connect Q and CK to the points with the same label in the circuit already built and tested.
- 5 Verify that A, B and C count up in binary when the switch is pressed. Use the LED and driver.

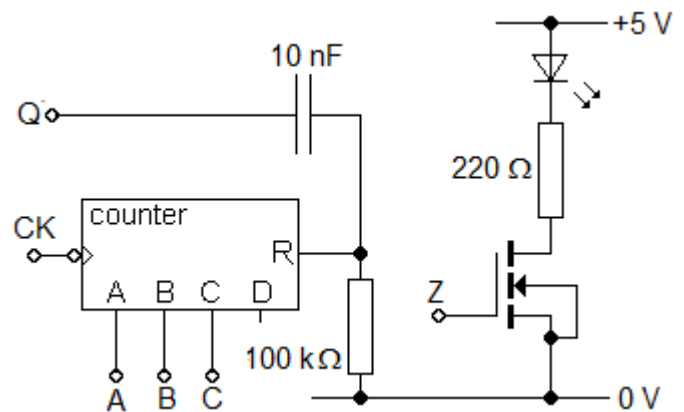

- 6 Add a 4051 multiplexer i.c. and OR gate as shown opposite. Don't connect them to the rest of the system yet.
- 7 Connect C, B and A to the binary counter. Verify that when the switch is pressed, the multiplexer outputs go high one one after the other for about 1 s at a time.

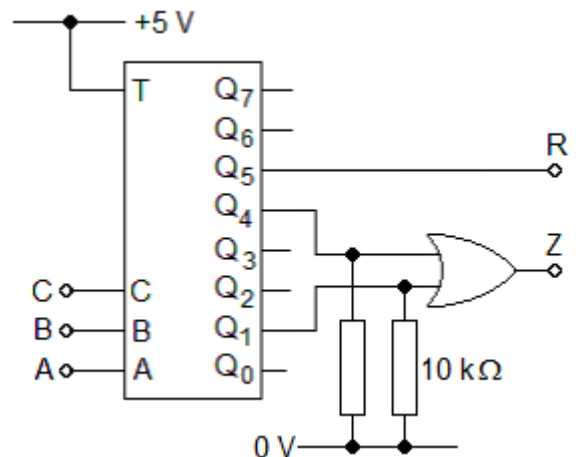

- 8 Finally, connect R and Z to the points with the same label in the rest of the circuit. If all is well, pressing the switch should result in a pair of one second pulses at Z, with a two second gap between them. Draw a timing diagram for Q and Z to summarise the behaviour of the system.

Designing one-shot sequencers

You are going to adapt the one-shot sequencer you have already assembled.

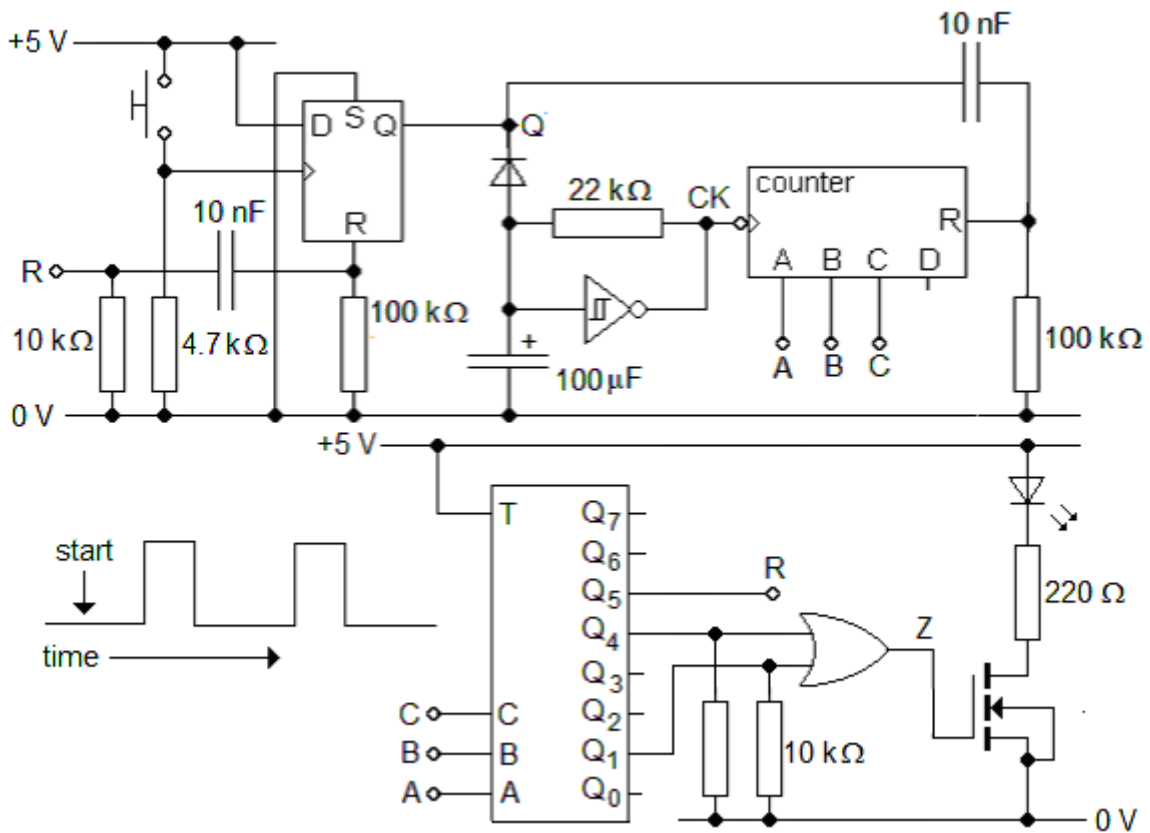

- 1 Adapt the circuit so that the sequence at Z is as shown in the timing diagram below. The whole sequence has to last for six seconds.

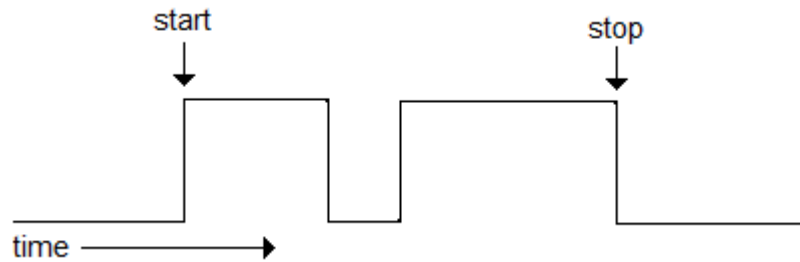

- 2 Adapt the circuit so that the sequence at Z is as shown below, with the whole sequence lasting for 14 s.

