

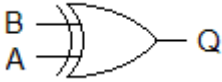

1 Link each Boolean **algebra** expression with its **logic gate** and **truth table**.

algebra	logic gate	truth table															
$Q = \bar{A} + \bar{B}$		<table border="1" style="border-collapse: collapse;"> <thead> <tr><th>B</th><th>A</th><th>Q</th></tr> </thead> <tbody> <tr><td>0</td><td>0</td><td>1</td></tr> <tr><td>0</td><td>1</td><td>0</td></tr> <tr><td>1</td><td>0</td><td>0</td></tr> <tr><td>1</td><td>1</td><td>0</td></tr> </tbody> </table>	B	A	Q	0	0	1	0	1	0	1	0	0	1	1	0
B	A	Q															
0	0	1															
0	1	0															
1	0	0															
1	1	0															
$Q = A\bar{B} + \bar{A}B$		<table border="1" style="border-collapse: collapse;"> <thead> <tr><th>B</th><th>A</th><th>Q</th></tr> </thead> <tbody> <tr><td>0</td><td>0</td><td>0</td></tr> <tr><td>0</td><td>1</td><td>1</td></tr> <tr><td>1</td><td>0</td><td>1</td></tr> <tr><td>1</td><td>1</td><td>0</td></tr> </tbody> </table>	B	A	Q	0	0	0	0	1	1	1	0	1	1	1	0
B	A	Q															
0	0	0															
0	1	1															
1	0	1															
1	1	0															
$Q = \bar{A}\bar{B}$		<table border="1" style="border-collapse: collapse;"> <thead> <tr><th>B</th><th>A</th><th>Q</th></tr> </thead> <tbody> <tr><td>0</td><td>0</td><td>1</td></tr> <tr><td>0</td><td>1</td><td>1</td></tr> <tr><td>1</td><td>0</td><td>1</td></tr> <tr><td>1</td><td>1</td><td>0</td></tr> </tbody> </table>	B	A	Q	0	0	1	0	1	1	1	0	1	1	1	0
B	A	Q															
0	0	1															
0	1	1															
1	0	1															
1	1	0															

2 Use NOT, AND and OR gates to design circuits which behave as described by these Boolean algebra expressions.

$$Q = X.Y + \bar{Z}$$

$$Q = \bar{X}.Y.Z + \bar{Y}.\bar{Z}$$

$$Q = \bar{Y} + X.Z + \bar{X}.\bar{Y}.\bar{Z}$$

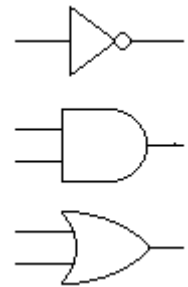

3 Link each **expression** on the left with its equivalent **sum of terms** on the right.

expression	sum of terms
$\overline{(W.X) + \bar{Y}}$	$\bar{W}.X$
$\overline{(W + \bar{Y}).X} + \overline{(W + \bar{X})}$	$\bar{W}.X.\bar{Y}$
$\overline{(W + X).(W + \bar{X} + Y)}$	$W + \bar{X}.\bar{Y}$
$Y.(W.X + \bar{W}) + \overline{(Y + (\bar{W}.X).Y)}$	$W.\bar{X} + W.\bar{Y}$
	$\bar{X}.Y + \bar{W}.Y$
	$X + \bar{W} + \bar{Y}$