

Making a monostable

You are going to make a monostable in stages so that you can see how it operates.

1 Start off by assembling this circuit.

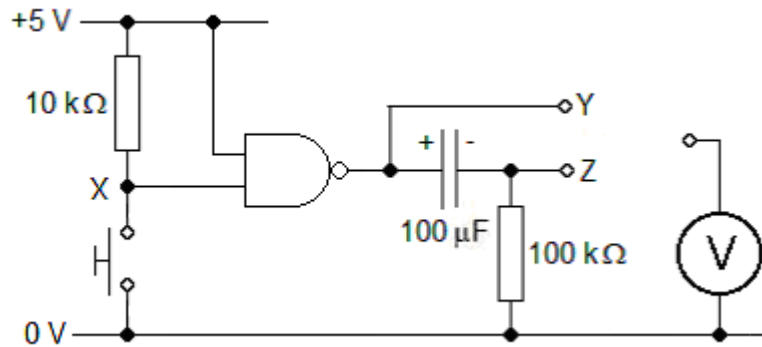

2 Use the voltmeter to verify that pressing the switch and holding it down makes

- X drop immediately to 0 V
- Y rise immediately to +5 V and stay there
- Z rise immediately to +5 V and then slowly drop back down to 0 V.

3 Hold the switch down for 30 s. Then release it. Use the voltmeter to verify that this makes

- X rise immediately to +5 V
- Y drop immediately to 0 V and stay there
- Z fall immediately to -5 V and slowly rise back up to 0 V.

4 Now add a second NAND gate, as shown below.

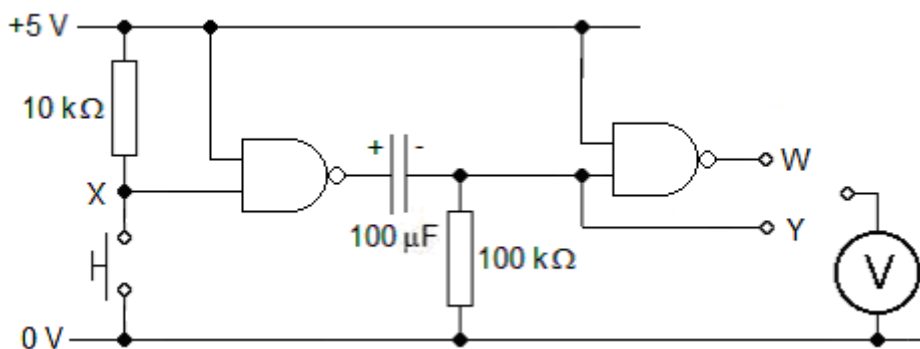

5 Use the voltmeter to verify that

- pressing the switch and holding it down makes W go low for about 7 s
- subsequent releasing of the switch has no effect on W
- releasing the switch does not produce a large negative spike at Y
- pressing the switch and releasing it while W is low makes W go high immediately.

6 Now add feedback from the second gate to the first, as shown below.

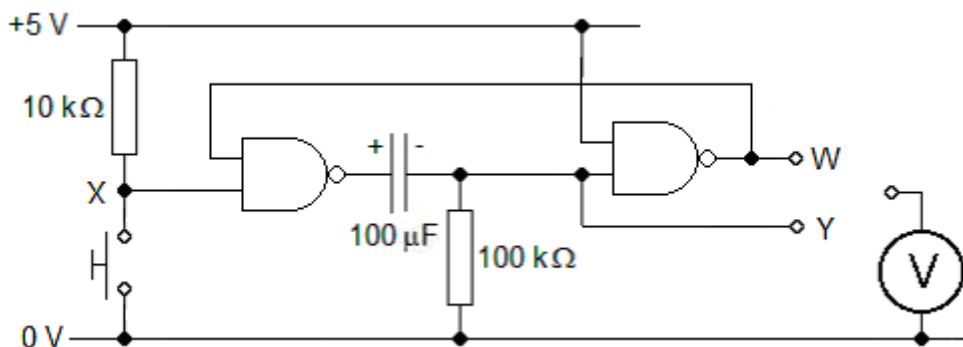

7 Use the voltmeter to verify that

- pressing the switch makes W go low for about 7 s
- releasing the switch has no effect on the signal at W.

8 Use a stopwatch to measure the time T for which W goes low each time that X goes low. Compare the result with the value calculated from $0.7RC$.

9 Measure the values of T for the values of R and C given in the table below.

R	C	T	$0.7RC$
100 k Ω	100 μ F		7 s
220 k Ω	100 μ F		
47 k Ω	1000 μ F		
470 k Ω	10 μ F		

10 Select values for R and C which should give T a value of 10 s. Try them out.

Multiple monostables

You are going to analyse and test systems which contain a pair of monostables.

1 Consider the system shown below.

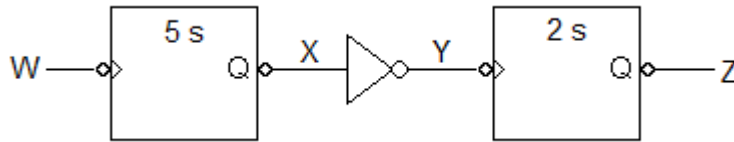

2 Assume that W is pulsed low for 1 s. Draw a timing diagram to show the signals at W, X, Y and Z when W is pulsed low.

3 Design a monostable whose output goes low for 5 s when its input is pulsed low.

4 Assemble it as shown below. The NOT gate acts as a driver for the LED and its series resistor, so that the state of X is not affected by current drawn from it.

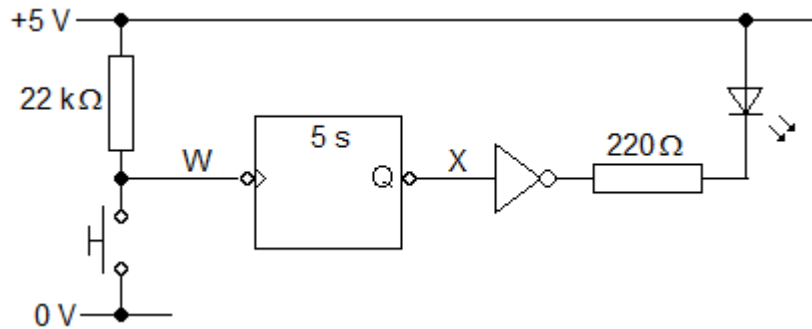

5 Verify that X goes low for 5 s each time W goes low.

6 Design, assemble and test a second monostable whose output Z goes low for 2 s when its input Y goes low.

7 Combine the two monostables with the NOT gate to build the whole system. Use a NOT gate and LED to monitor its output. Does it behave as you predicted?

8 Predict the behaviour of the system shown below. Then build it and see what it does.

