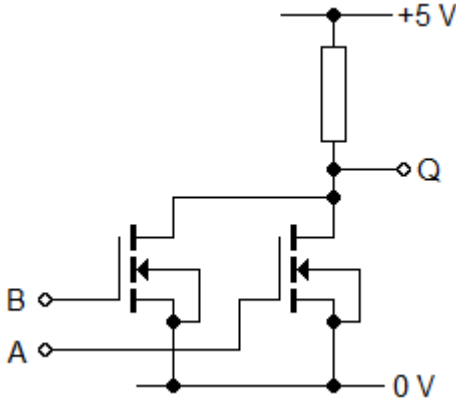

Overview

In this unit your students should:

- find out the effect of making a logic gate sink or source current
- learn how to use a MOSFET as a driver
- investigate the transfer characteristics of a MOSFET

This should not require more than 3 hours of class time.

Hour	Suggested Activity
1	<p>The practical Sourcing and sinking current from a NOT gate sets the scene for this unit. As well as giving them some practice at wiring up circuits on breadboard from circuit diagrams and data sheets, it should show them that logic gates can't handle much power at their outputs.</p> <p>Introduce the MOSFET as a voltage-controlled resistor. You could show how they can be used to make NOT and NOR gates, but this is beyond the AS specification.</p>  <p>Ask students to answer question 1 of the Switching Outputs exercises before the next session.</p>
2	<p>Discuss their answers to question 1 before starting them off on the Transfer characteristic of a MOSFET driver practical. The IRF510 is a high power MOSFET, so it has a measurable drain-source resistance when it is switched on. Encourage them to make enough measurements to draw a smooth curve through the points on the graph.</p> <p>As they finish, they could start working on questions 2 and 3 of the Switching Outputs exercises.</p> <p>Ask students to answer question 1 on page 16 of the text book, as well as finish off the exercises before the next session.</p>
3	<p>Launch students straight into the Touch controlled motor practical. An IRF510 MOSFET is the safest type to use - the current in a stalled motor could overwhelm a 2N7000 which is rated at only 350 mA. You could use a high power lamp (such as the ones used in ray boxes), but be prepared for hot MOSFETs!</p> <p>Your students should now be able to answer questions 2 and 3 on page 16 of the text book before the next session.</p>

Model Answers

1 (a)

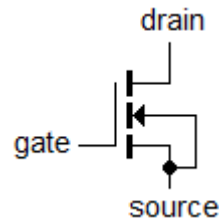

(b) Charge should only flow from drain to source. The drain-source resistance is infinite when the gate-source voltage is below the threshold value, falling rapidly to a steady low value as the gate-source voltage rises above the threshold value.

2 (a)

The outputs of logic gates can only supply a few milliamps at 5 V. Motors, heaters and lamps often require much larger currents and different voltages.

(b)

(c) One or both of the inputs of the gate must be low. This makes the output of the gate high, raising the gate above its threshold voltage. This reduces the drain-source resistance of the MOSFET, allowing charge to flow through the motor. Most of the 9 V is dropped across the motor, so power is delivered to it.

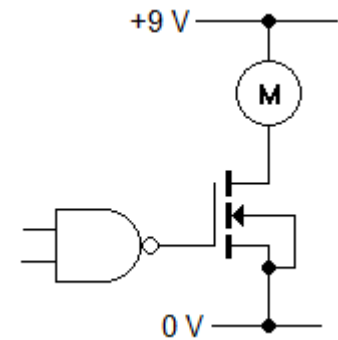

3 (a)

2.2 V

(b)

The drain-source resistance = 2 Ω.

So the drain-source voltage $V = IR = 8.2 \times 2 = 16.4$ V
and the power $P = VI = 16.4 \times 8.2 = 134$ W.