

Time sharing

You are going to assemble a system which uses TDM to transmit four different one-bit signals down a single data link. Here is the block diagram for the transmitter and receiver.

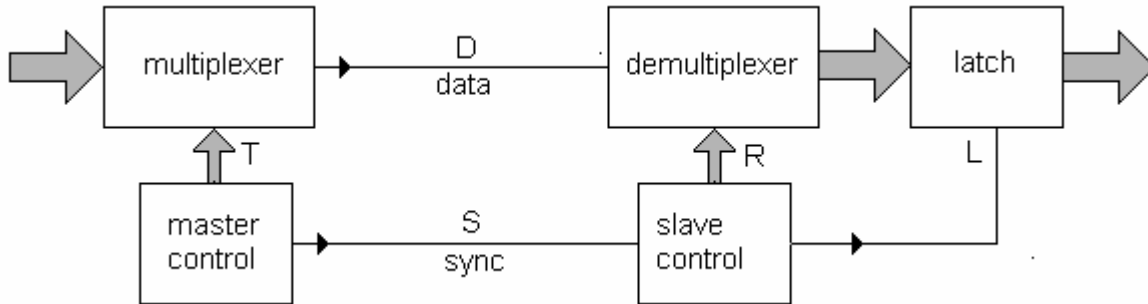

- 1 Assemble this master control block first. T_1 and T_0 will provide the address inputs for the multiplexer. They should have frequencies of 2 kHz and 4 kHz respectively.

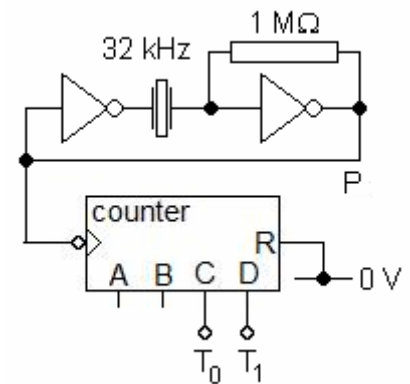

- 2 Add the multiplexer shown below. Hold the C input of the 4051 i.c. low and use the Q_3, Q_2, Q_1 and Q_0 inputs.

- 3 Connect one channel of an oscilloscope to T_1 . Arrange for at least one cycle of the signal can be seen on the screen. Then use the other channel to look at D. Press and release each of the switches in turn. If all is well, each of the four input signals I_n should be connected to D in a set of different time slots.

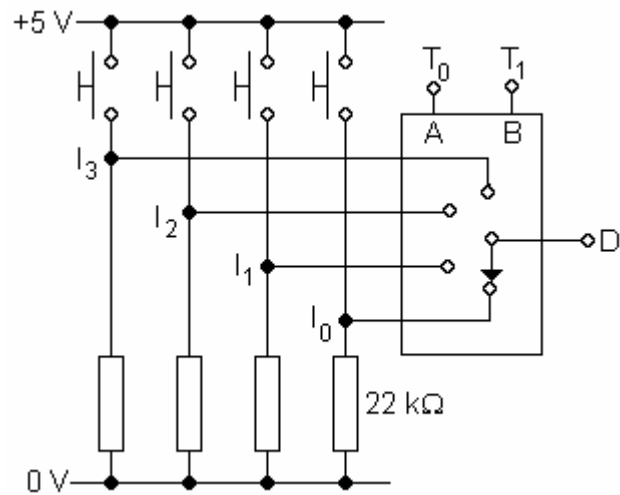

- 4 Complete the timing diagram below.

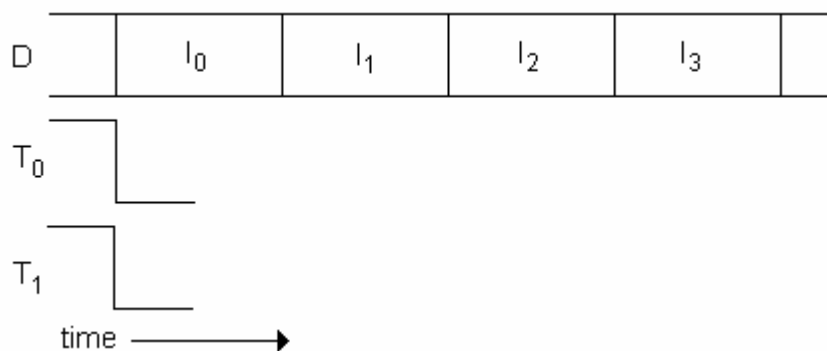

5 Now assemble the demultiplexer, latch and display of the receiver on a second breadboard. Make sure that you connect S and R of each flip-flop to an appropriate supply rail.

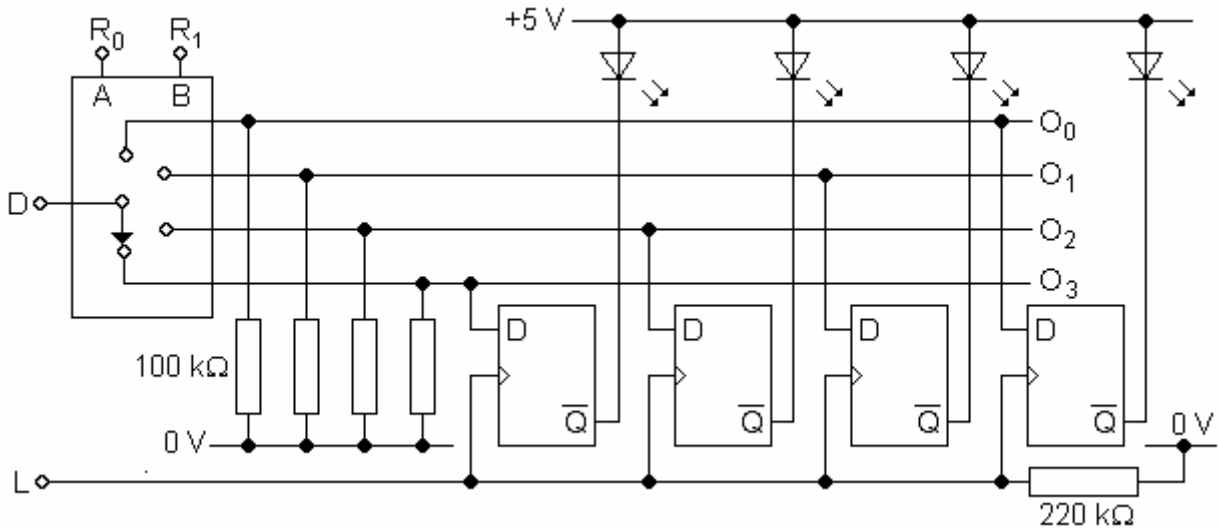

6 Test the sub-system as follows.

- Connect R₁ and R₀ to the 0 V supply rail. Connect D to +5 V.
- Connect L to +5 V. If all is well, only O₀ should go high.
- Connect D to 0 V and pulse L high to reset all output lines.
- Repeat for the other three combinations of R₁ and R₀.

7 The slave control sub-system opposite is essentially the same as the master control sub-system that you have already built. The input S will eventually receive synchronisation pulses from the transmitter on the other breadboard.

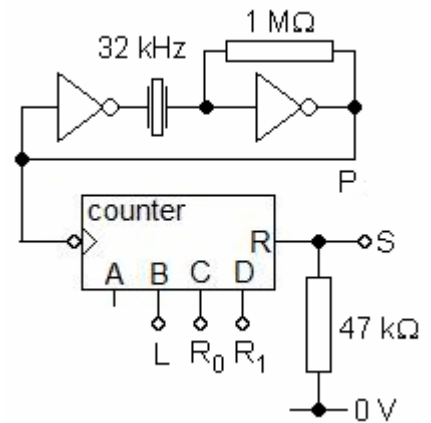

8 Complete timing diagram below for the receiver.

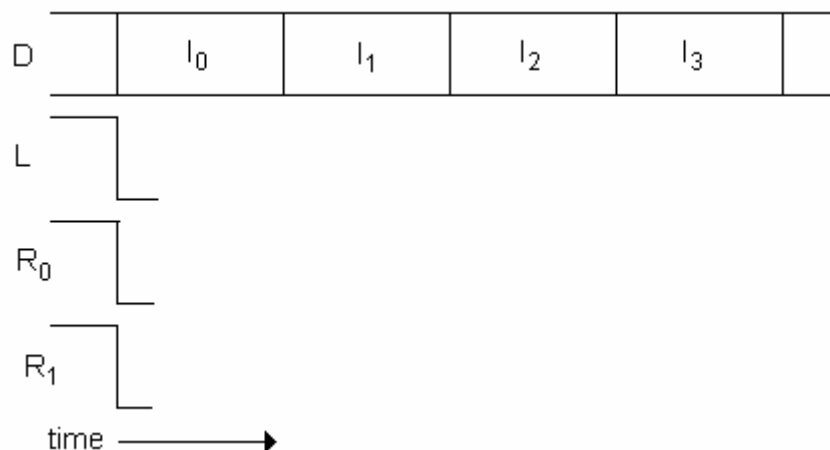

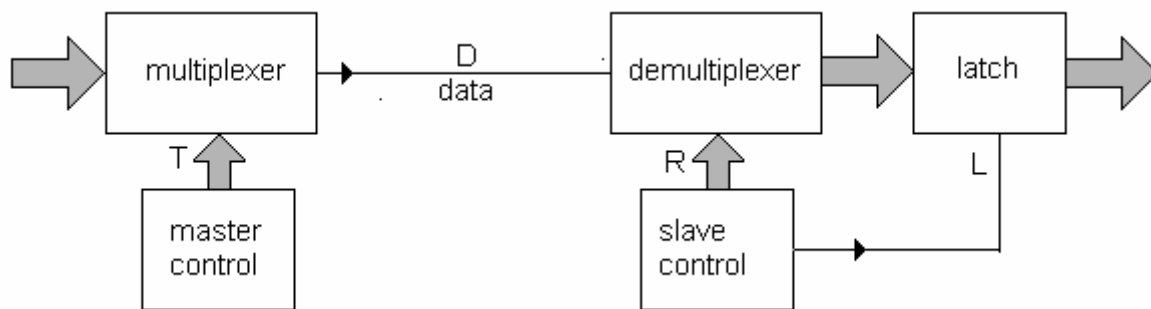

- 9 Now connect the slave control system to the demultiplexer, latch and display, to make the receiver shown on the right of the block diagram. Then connect the data line D between the transmitter and the receiver. If all is well, pressing and releasing switches in the transmitter should result in changes on the LED display. You should find that each switch controls just one LED, but probably the wrong one. This is because the transmitter and receiver have not yet been synchronised.
- 10 The synchronisation signal S is a brief 5 V pulse every time T_1 falls from high to low. You will need to design the monostable so that it has a pulse duration of $7 \mu\text{s}$, as shown below.

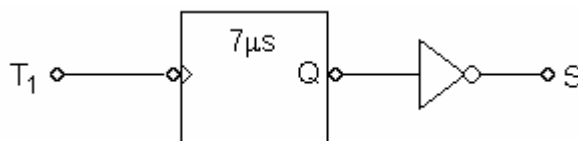

- 11 Assemble the synchronisation sub-system shown above. Put it on the transmitter's breadboard. Use an oscilloscope to verify that S produces a short 5 V pulse on each falling edge of T_1 . Add the S signal to the timing diagrams above.
- 12 Connect the sync signal between the transmitter and receiver. If all is well, each switch in the transmitter should now control the correct LED in the receiver.
- 13 If you have time, arrange for your transmitter to send signals to someone else's receiver and vice-versa. You should be able to communicate in the following code, using the 16 different four-bit words to represent the most-used letters of the alphabet in English.

0000	space
0001	E
0010	A
0011	R

0100	I
0101	O
0110	T
0111	N

1000	S
1001	L
1010	C
1011	U

1100	D
1101	P
1110	M
1111	H