

Refresh rate

You are going to find out how fast an image needs to be refreshed for it to be flicker-free.

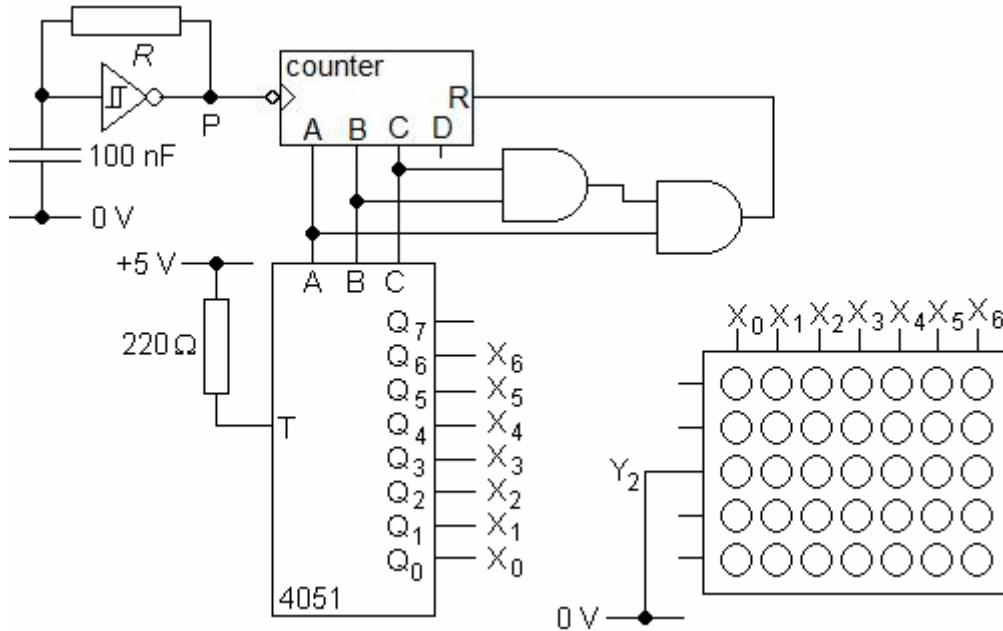

- 1 Start off by assembling the oscillator with $R = 1\text{ M}\Omega$, so that P has a frequency of about 5 Hz.

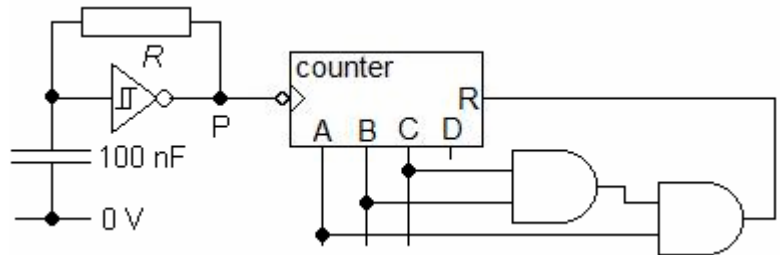

- 2 Then add the 4024 binary counter and AND gates as shown above. Use an oscilloscope to verify that the counter is operating correctly. In particular, C should go high about once every second.

- 3 Now add the 4051 demultiplexer, as shown opposite. Use the oscilloscope to check that the outputs Q_0 to Q_6 are connected to T about once a second.

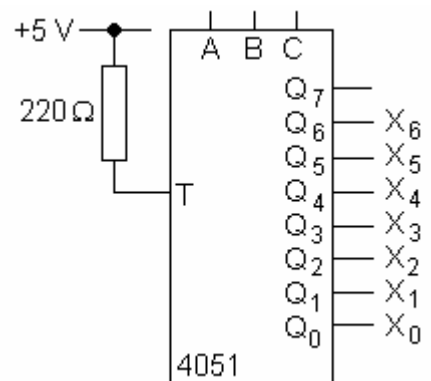

- 4 Finally, connect the dot matrix LED to the multiplexer, as shown above. Leave all of the Y inputs floating except for Y_2 .

- 5 If all is well, the display should show a single dot moving quickly and continuously from left to right at a rate of about once a second.

- 6 Replace R with $470\text{ k}\Omega$, $220\text{ k}\Omega$, $100\text{ k}\Omega$, $47\text{ k}\Omega$ and $22\text{ k}\Omega$ in turn. You should find that only the last value gives you a flicker-free image of a line instead of moving dots.

Raster scan

You are going to investigate how single time-varying signal and a raster scan can be used to create a two-dimensional picture on a dot matrix LED. Here is the basic circuit. You already have most of it on your breadboard.

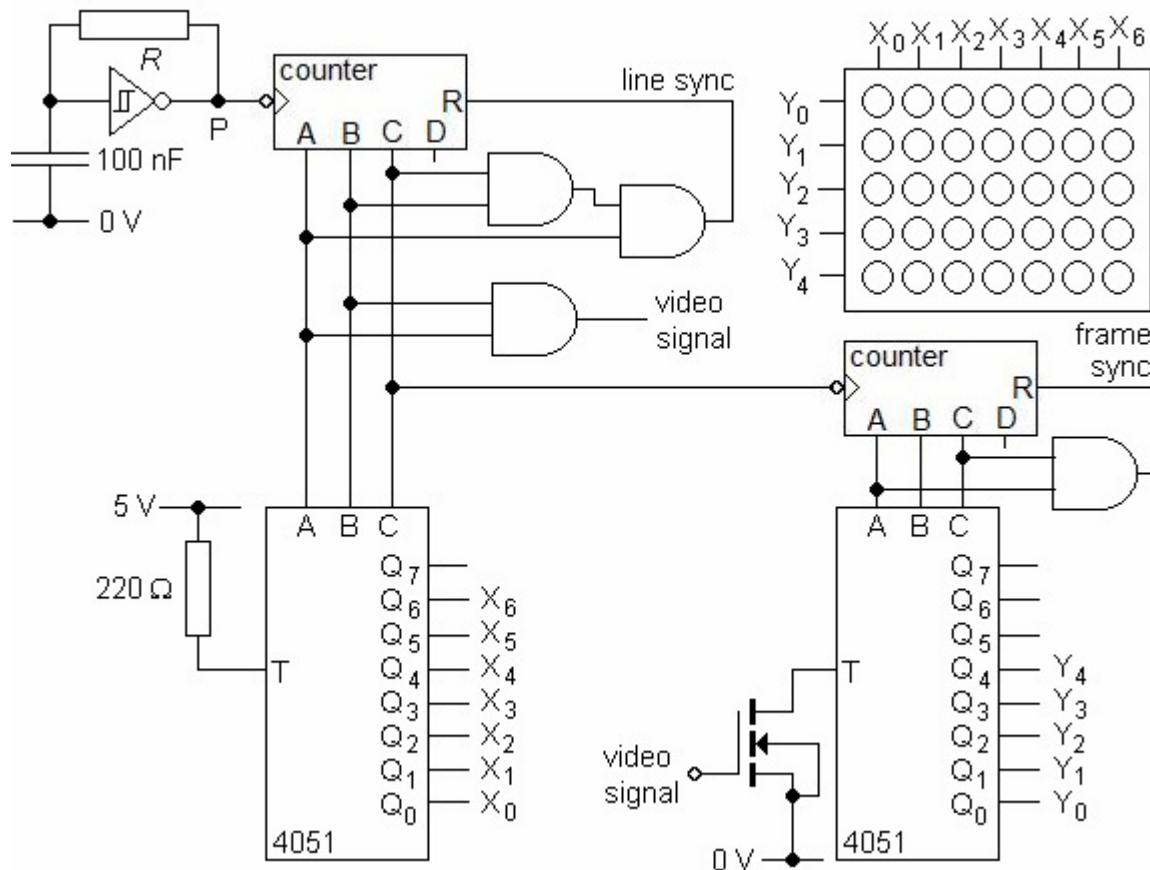

- 1 Make $R = 1 \text{ M}\Omega$ so that P has a frequency of about 5 Hz.
- 2 The counter on the left controls which column of LEDs (X_0 to X_6) is being accessed. Add the counter on the left which controls which row of LEDs (Y_0 to Y_4) is being accessed. Use an oscilloscope to check that its outputs (A_Y , B_Y and C_Y) behave as expected.
- 3 Add the 4051 multiplexer and MOSFET which sinks current from one row of LEDs at a time. Hold the gate of the MOSFET high. If all is well, the LEDs should glow one after the other in a raster scan.
- 4 Now connect the video signal to B.A as generated by the AND gate in the centre of the circuit diagram. Reduce the value of R in stages until you have a flicker-free image of a single vertical lines down the centre of the display. $R = 4.7 \text{ k}\Omega$ should do.

- 5 Use AND and OR gates to combine the counter output signals to display these images on the dot matrix LEDs.

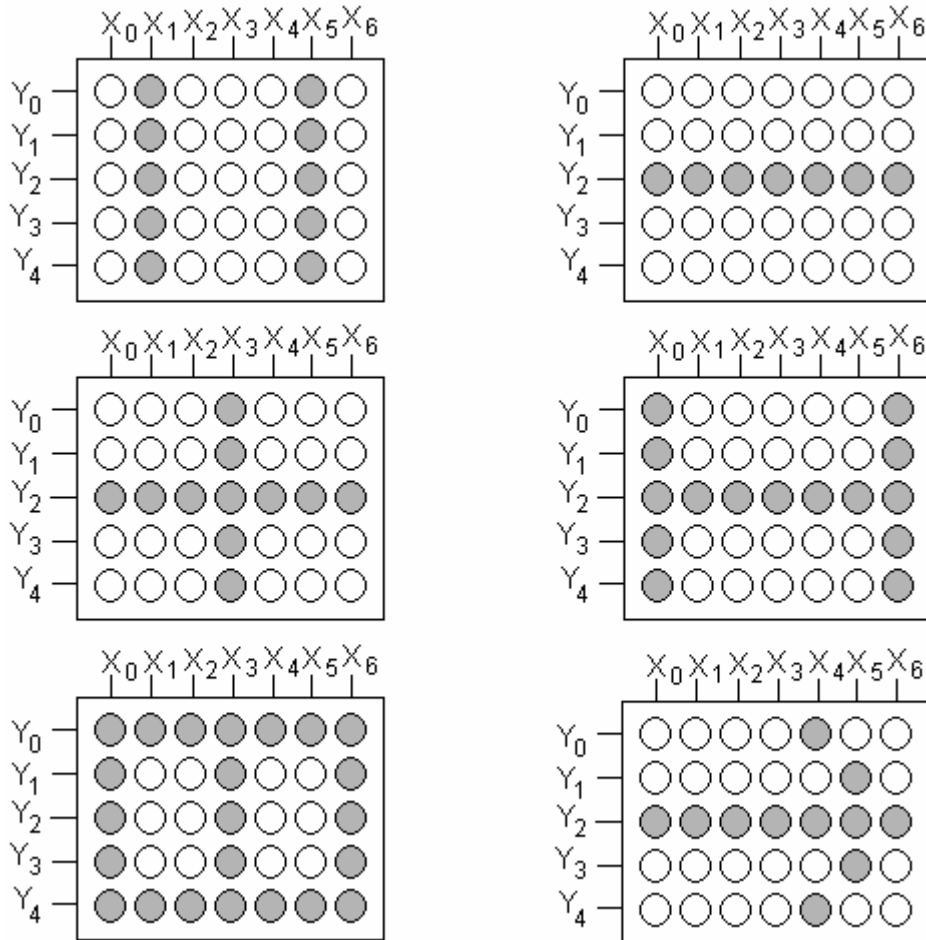

Square wave components

You are going to use an Excel spreadsheet called SPECTRUM.XLS to see how a square wave signal can be built up out of a number of different sine wave signals.

- 1 Open up the workbook SPECTRUM.XLS at the DATA spreadsheet. At the top-left-hand corner of the sheet are columns for entering the amplitude A and frequency F of up to ten different sine wave signals. The DATA sheet calculates the values of each signal over 2.50 ms before adding them all together to create a composite signal plotted on the WAVEFORM sheet. The frequency spectrum of the composite signal is plotted (as dots) on the SPECTRUM sheet.
- 2 Enter a sine wave signal of amplitude +1.60 V and frequency 1.0 kHz. Press f9 and view the waveform and its frequency spectrum.
- 3 Add another signal of amplitude +1.25 V and frequency 0.0 kHz. Press f9 and view the composite signal waveform. Does it start to look like a square wave?
- 4 Add a third signal of amplitude $-1.25 / 3 = -0.53$ V and frequency 3.0 kHz. The composite signal should now be closer to a square wave than before.
- 5 The fourth signal to be added has an amplitude of $+1.25 / 5 = +0.32$ V and a frequency of 5.0 kHz.
- 6 The fifth signal to be added has an amplitude of $-1.25 / 7 = -0.23$ V and a frequency of 7.0 kHz.
- 7 Press f9 and look at the composite waveform. It should be a good approximation to a square wave alternating between 0 V and +2.5 V at 1 kHz. Keep adding higher frequency components to get an even better approximation.
- 8 Use the spreadsheet to create the following square waves:
 - alternating between 0 V and 1.0 V at a frequency of 2.0 kHz
 - alternating between 0 V and -2.0 V at a frequency of 0.5 kHz
 - alternating between +1.5 V and -1.5 V at a frequency of 5 kHz